

# Accuphase

DIGITAL FREQUENCY DIVIDING NETWORK

## DF-65

- High-speed DSP realizes fully digital signal processing in channel divider units
- Standard configuration allows 4-channel (4-way) system setup
- 59 selectable cutoff frequency points
- Highly accurate 96 dB/oct attenuation slope
- Time alignment function allows delay time setting in 0.5-cm steps
- Delay compensator offsets signal delays in filter circuitry
- Further refined MDS++ D/A converter
- Selectable monophonic output mode for further enhanced specifications







# Multi-channel divider with fully digital signal processing realizes the ultimate in audio enjoyment with outstanding performance, sophisticated features and intuitive operation

The Digital Frequency Dividing Network DF-65 harnesses the very best of digital technology in every aspect, including a high-speed 40-bit floating point DSP. The standard unit configuration supports signal processing for up to four-way systems. Highly accurate digital filters offer a choice of 59 cutoff frequency points and up to 96 dB/octave attenuation. Integrated time alignment function adjustable in 0.5-cm steps, and delay compensator for automatically offsetting any filter circuit delays. Monophonic output mode provides high versatility for various configurations.

## Innovative Technology

**High-speed, high-precision DSP implements fully digital signal processing**  
 Designed to serve as the core component of a multi-amped system, the channel divider DF-65 features high-speed digital signal processing with amazing power. Latest digital circuit topology and advanced technology come together in a floating-point DSP that has a 32-bit mantissa and 8-bit exponent section, serving as digital filter. The division into mantissa and exponent prevents errors even when handling very small values. This results in dramatically improved dynamic range and superior precision, allowing very steep cutoff slope settings of 48 dB or 96 dB per octave. All other functions including phase, delay, and level control are also implemented in the digital domain. The result is ultra-precise filtering free from adverse effects by temperature changes or aging.

**59 selectable cutoff frequency points**  
 Filter frequency points can be set over the range from 31.5 Hz to 22.4 kHz in 1/6-octave intervals. In addition, 10, 20, and 290 Hz points are also provided, resulting in a total of 59 points. Each divider unit is fully flexible and allows independent selection of lower and upper cutoff frequency.

**Six filter slope characteristics with up to 96 dB attenuation per octave**  
 The filter attenuation characteristics can be set to 6 dB, 12 dB, 18 dB, 24 dB, 48 dB, or 96 dB per octave. The 96 dB/octave setting in particular allows the driver unit to reproduce only its intended frequency without being affected by adjacent frequency bands. This makes it possible to create a multi-amped system that takes musical accuracy to a wholly new level.

**Built-in cutoff frequencies (Hz)**  
 Cutoff characteristics: -3.0 dB, 59 points

10	20	31.5	35.5	40
45	50	56	63	71
80	90	100	112	125
140	160	180	200	224
250	280	290	315	355
400	500	560	630	710
800	900	1000	1120	1250
1400	1600	1800	2000	2240
2500	2800	3150	3550	4000
5000	5600	6300	7100	8000
9000	10k	11.2k	12.5k	14k
16k	18k	20k	22.4k	

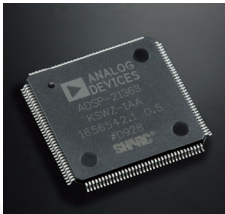
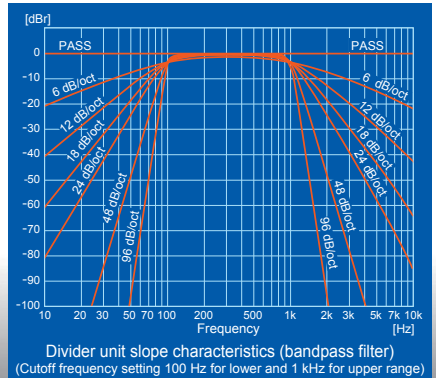

High-speed 40-bit floating point DSP

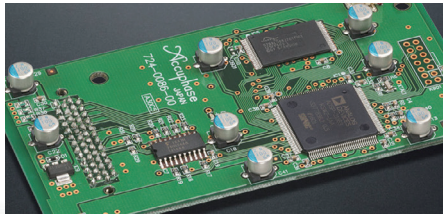

Assembly with high-speed DSP chip

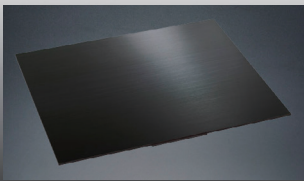

Thick aluminum top plate with elegant hairline finish





**Block Diagram of MDS++ Converter**

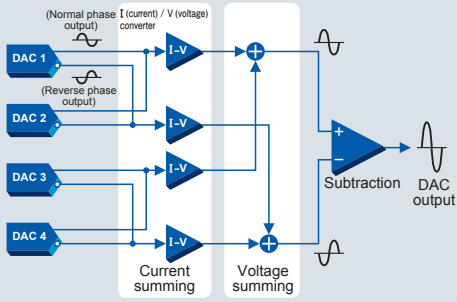

**Time Alignment Principle**

**<Time alignment using delay>**

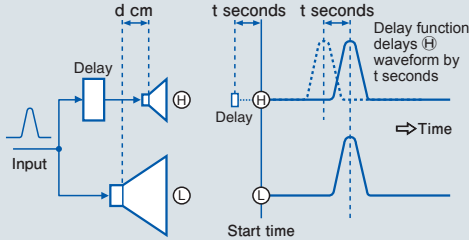

Sound sources (diaphragms) of speaker units (L) and (R) are d centimeters apart

Delay ensures that (L) and (R) signals arrive at the ear at the same time

**Reference**

Speed of sound =  $331.5 + 0.607 T$  [m/sec] T: temperature (°C)  
Consequently, at 20°C, sound travels at about 343.5 m/sec.

In the example above, when the DELAY function for (H) is set to d cm, the signal start for (H) will be delayed by  $t = d/343.50$  seconds, causing the sound from (L) and (H) to reach the listener at the same time.

**High-performance Hyperstream™ DAC used for MDS++**

MDS (Multiple Delta Sigma) is a revolutionary design that employs multiple delta-sigma type D/A converters connected in parallel, for drastically improved performance. In the DF-65, four Hyperstream™ DAC chips (ES9018S made by ESS Technology) of the latest generation are driven in parallel. Compared to a single converter, this results in an overall performance improvement by a factor of  $2 (= \sqrt{4})$ .

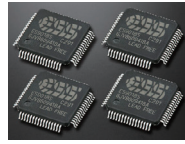

**Time alignment function allows delay adjustment in 0.5-cm steps**

The DF-65 incorporates a DELAY function that uses digital signal processing to electrically adjust the time when the sound from each driver reaches the listener. Normally, a delay would be expressed as a time value, but since the delay here is caused by spatial distance, the DF-65 converts it into a distance value (cm) for display.

**Digital attenuator with setting range from -40.0 dB to +12.0 dB (in 0.1dB steps) allows precise level adjustments for left and right channels.**

**"Analog ATT" function can be activated for specific channels to reduce residual noise when using high-efficiency speaker units (ON: -10 dB).**

**Versatile choice of input connectors: Coaxial, optical, and HS-LINK for digital signals. Line and balanced for analog signals**

**"Full Level Output Protection" function safeguards the speakers if a digital signal without volume control data is input (Output level is reduced to -40 dB).**

**Unused divider units can be set to OFF (all display elements and LED indicators are out).**

**Independent phase switching for left and right channel (4 patterns).**

- NOR.NOR.** Left/Right: Normal phase
- REV.REV.** Left/Right: Inverted phase
- NOR.REV.** Left: Normal phase, Right: Inverted phase
- REV.NOR.** Left: Inverted phase, Right: Normal phase

**Memory feature allows saving and recalling function settings.**

**System backup function allows returning the entire system to a previous condition.**

**Safety Lock prevents inadvertently changing any settings.**

**Display indication can show predefined strings or custom strings entered by the user (max. 8 characters, character set 97 characters).**

**Elegant side panels with natural wood grain finish**

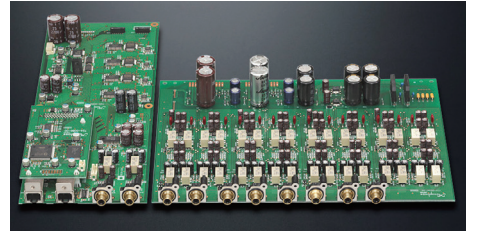

Assembly with HS-LINK digital input and output connectors, line input connectors, MDS++ D/A converters for 4 channels, line output connectors etc.

**Default settings of each unit**

Function		Display indication	
LOWER FREQUENCY	UPPER FREQUENCY	7100Hz	PASS
LOWER SLOPE	UPPER SLOPE	12dB/oct	---
LEVEL Factory default: L=R simultaneous mode	DELAY Factory default: L=R simultaneous mode	-40.0*	0.0
DELAY COMP	PHASE	ON 0	NOR.NOR.
OUTPUT	ASSIGNMENT	ON	SUPER-H
MODE		STEREO	

● (●) symbol at top right of level indication is shown when "Full Level Output Protection" function is set to ON.

**Delay compensator function of DF-65 (providing automatic compensation for signal delays)**

**<Operation principle of delay compensator>**

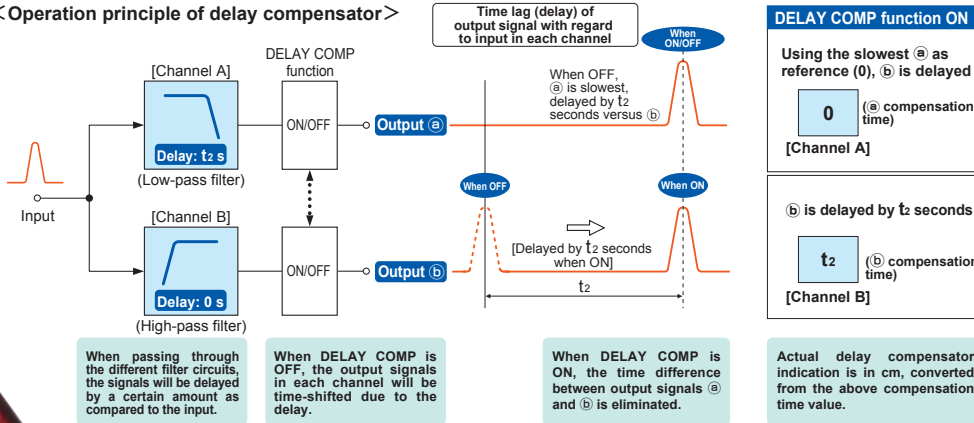

When a signal passes a filter circuit, a delay necessarily occurs. The "DELAY COMP" function compensates for such delays. The illustration at left uses a 2-way system as an example to show how the delay compensator works.

Regardless of whether a circuit is analog or digital, when the signal has to pass through a filter, the output will be delayed by a certain amount, causing a delay in step response and impulse response.

Generally, a low-pass filter will have more delay. The DF-65 therefore only provides compensation when low-pass filtering is used.

The lower the filter frequency and the steeper the filter slope, the longer the delay.

**ON** : The DF-65 calculates and displays the theoretical delay time, and automatically provides compensation. (Default setting)

**OFF** : The DF-65 calculates and displays the theoretical delay time for reference, and the user can manually set any desired value.

**DF-65 Block Diagram**

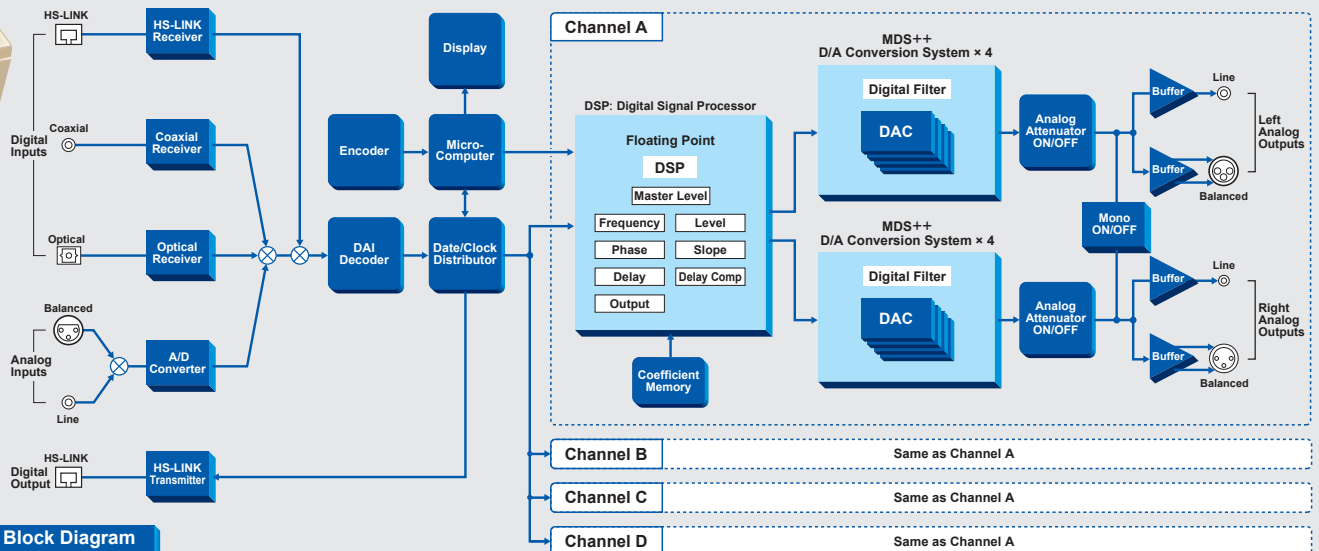

## Divider units (common design for all 4 units)

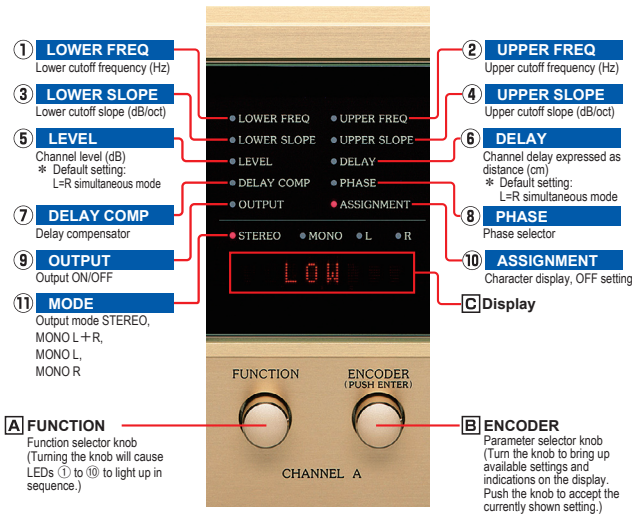

### Intuitive and innovative operation

Turn the FUNCTION knob [A] to select an item from ① to ⑪.  
Turn the ENCODER knob [B] to bring up a value or setting on the display [C], and push the knob to accept it.

## Center unit

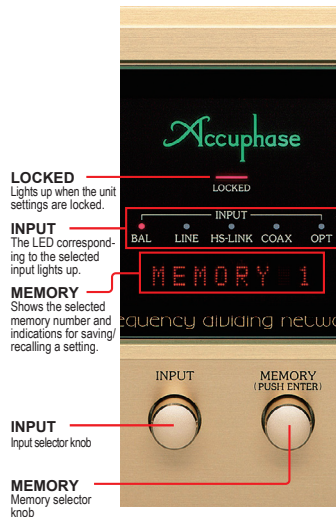

Turn the INPUT knob to select an input (respective LED lights up).  
Turn the MEMORY knob to select a memory number from 1 to 5, and push the knob to perform save or recall.

## Usage examples of DF-65 in monophonic mode

Each divider unit can be set to one of four output modes: **STEREO**, **MONO L+R**, **MONO L**, **MONO R**.  
When one of the MONO positions is selected, the DAC output for the left and right channel circuits in the unit are combined and driven in parallel, which can be used to achieve a further reduction of residual noise.

### <Usage examples of DF-65 in monophonic mode>

① **2-way system with right/left in monophonic mode**  
This setup uses the four divider units of a single DF-65 for a 2-way system, with two units set to "MONO L" and the other two units set to "MONO R".

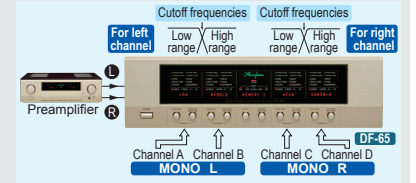

② **Subwoofer (3D) system**

Mixing the ultra-low frequency signals of the left and right channel can be used to improve performance of a system with a single subwoofer. Set the output mode for channel A to "MONO L+R".

③ **2-way to 4-way system with two DF-65 in monophonic mode**

Setting the divider units of the first DF-65 to "MONO L" and the divider units of the second DF-65 to "MONO R" allows multi-amping for a 2-way to 4-way system using the monophonic specifications.

## Front Panel

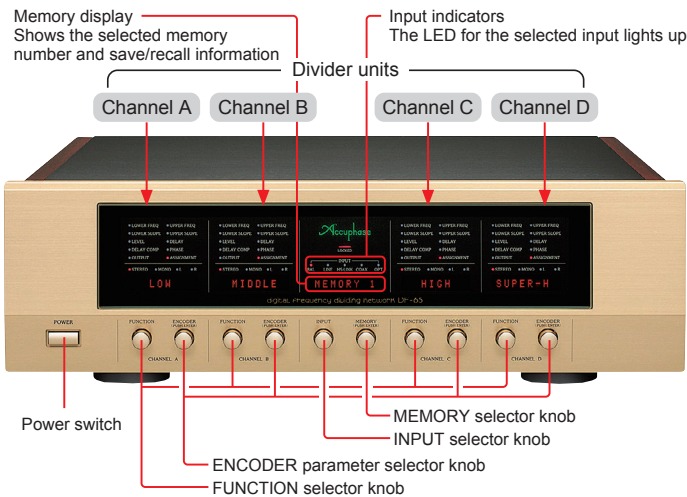

## Rear Panel

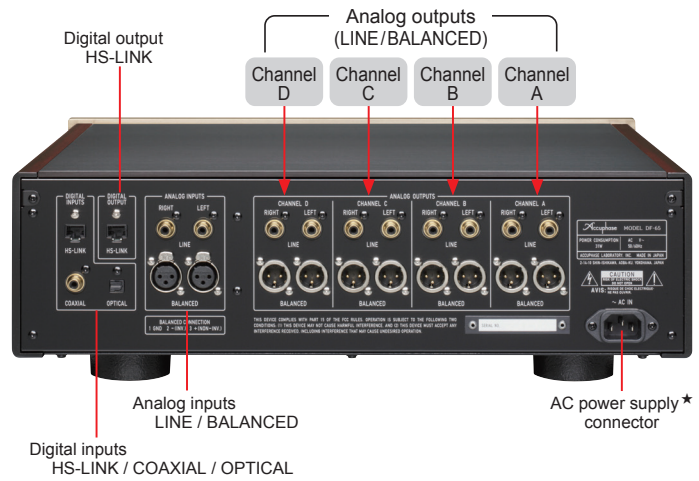

## DF-65 Guaranteed Specifications [Guaranteed specifications measured in compliance with JEITA standard method CP-2150]

### Digital Inputs

- COAXIAL Format: IEC 60958/AES3 compliant  
Sampling frequencies 32 kHz to 192 kHz (16 to 24 bits, 2-channel PCM)
- OPTICAL Format: JEITA CP-1212  
Sampling frequencies 32 kHz to 96 kHz (16 to 24 bits, 2-channel PCM)
- HS-LINK Connector: RJ-45, HS-LINK cable
  - Ver. 1 Sampling frequencies 32 kHz to 192 kHz (24 bits, 2-channel PCM)
  - Ver. 2 Sampling frequencies 32 kHz to 384 kHz (32 bits, 2-channel PCM)  
(352.8 kHz and 384 kHz are converted to 176.4 kHz and 192 kHz respectively.)

### Analog Inputs

- Maximum input level 3.7 V (1 kHz, 2.5 V output)
- Input impedance BALANCED: 40 kilohms  
LINE: 20 kilohms
- A/D converter Principle: 1-bit delta sigma modulation  
Sampling frequency: 176.4 kHz  
Quantization: 24 bits

### Digital Output

- HS-LINK Connector: RJ-45, dedicated HS-LINK cable

### Frequency Response

- 2.0 to 50,000 Hz +0 -3 dB

### D/A Converter

- Quantization: 32 bits
- STEREO operation: 4MDS++ type
- MONO operation: 8MDS++ type

### THD

- 0.0007% (20 to 20,000 Hz)

### S/N Ratio

	STEREO operation	MONO operation
COAXIAL/OPTICAL	121 dB	123 dB
HS-LINK	121 dB	123 dB
Analog Input	116 dB	117 dB

### Dynamic Range

118 dB

### Channel Separation

108 dB (20 to 20,000 Hz)

### Slope Characteristics

6 dB/octave, 12 dB/octave, 18 dB/octave  
24 dB/octave, 48 dB/octave, 96 dB/octave  
\* When cutoff frequency is 10 Hz: 48 dB/octave, 96 dB/octave not available  
20 Hz: 96 dB/octave not available

### Delay (converted into distance)

0 to ±3,000 cm (0.5-cm steps)  
\* Independent settings for left and right possible.  
\* Delay value range limit (absolute value) for all channels is 3,000 cm.

### Level Adjustment Range

"Analog ATT" OFF: -40 to +12.0 dB (0.1-dB steps)  
"Analog ATT" ON: -50 to +2.0 dB (0.1-dB steps)  
\* Independent settings for left and right possible.

### Output Voltage/Output Impedance

BALANCED: 2.5 V, 50 ohms, balanced XLR connector  
LINE: 2.5 V, 50 ohms, RCA-type phono connector

### Minimum Load Impedance

BALANCED/LINE 600 ohms

### Power Requirements

120/220/230 V AC, 50/60 Hz

### Power Consumption

31 watts

### Maximum Dimensions

Width 465 mm (18.31")  
Height 151 mm (5.95")  
Depth 396 mm (15.59")

### Mass

15.1 kg (33.3 lbs) net  
21.0 kg (46.3 lbs) in shipping carton

### Remarks

- \* This product is available in versions for 120/220/230 V AC. Make sure that the voltage shown on the rear panel matches the AC line voltage in your area.
- \* The 230 V version has an Eco Mode that switches power off after 120 minutes of inactivity.
- \* The shape of the AC inlet and plug of the supplied power cord depends on the voltage rating and destination country.

### Supplied accessories

- AC power cord
- Cleaning cloth

